

SG-LS SERIES

The **LENS SHIELD** accessory for safety light curtains, composed of a PMMA Altuglas plate that can be mounted on the front glass of the safety light, ensures an effective protection against dust, chips and incandescent drops, deriving from material working near the safety light curtain.

Thanks to the unique profile, available in different lengths, the accessory **suits all the models of the SG2, SG4 and SE series**. The accessory can be easily installed thanks to the fixing brackets supplied in the package that exploit the side groove of the safety light curtain. It can also be quickly replaced when the glass is damaged.



SENSORS

HIGHLIGHTS

- PMMA Altuglas 3mm plate
- Protects front glass of the light curtain from dust, chips and incandescent drops
- One profile available in different lengths ideal for all models of the SG2, SG4 and SE series (150–1800mm)
- Doesn't leave glue deposits or other residual material on the light curtain

APPLICATIONS

The SG-LS accessory is particularly suitable in working areas characterized by chips or incandescent drops deriving from material working or welding such as:

- Punching machines
- Milling machines
- Welding machines

Five plates are supplied in the package that supply adequate replacements even in presence of extremely high wear.

TECHNICAL DATA

Protected height*:	150..1800mm
	2, 3, 4 beams
Housing material:	PMMA Altuglas
Thickness	3 mm
Reduction factor of the op.distance*:	10 % for each Lens Shield installed
* technical data referred to safety light curtain where the accessory is mounted	

DIMENSIONS

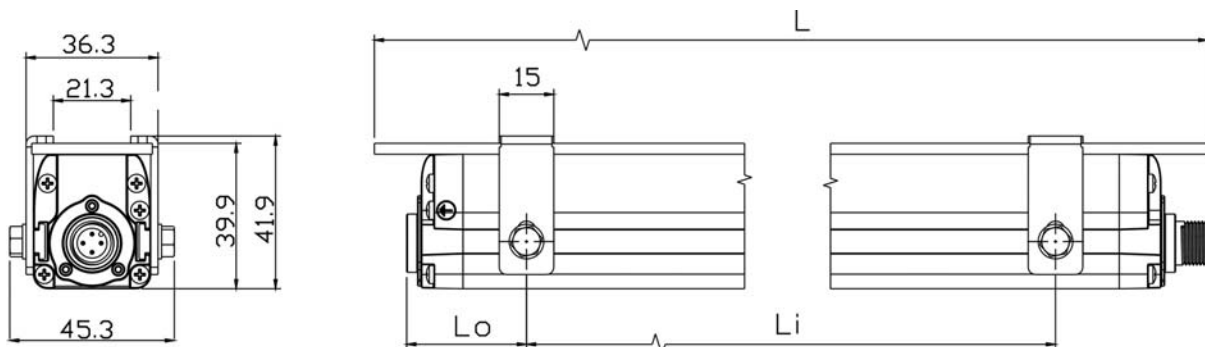

Measurement in mm									
SG2, SG4B, SE Hand/Finger protection					SE Body protection				
	VERS.	L	Li	Lo	VERS.	L	U	Lo	
I 2+2 brackets	015	245	160	30	2r 050	642	490	75	I 3+3 brackets
	030	392	345	45	3r 080	942	640	175	
	045	540	400	60	4r 090	1042	660	200	
	060	686	520	75					
	075	832	590	115					
I 3+3 brackets	090	980	640	175	4r 120	1342	480	200	
	105	1126	740	200					
	120	1274	845	200					
	135	1422	920	200					
	150	1568	995	200					
	165	1715	1070	200					
	180	1860	1145	200					

MODELS

MODEL	DESCRIPTION	ORDER N°
SG-LS 150	lens shield 150	95ASE2000
SG-LS 300	lens shield 300	95ASE2001
SG-LS 450	lens shield 450	95ASE2002
SG-LS 600	lens shield 600	95ASE2003
SG-LS 750	lens shield 750	95ASE2004
SG-LS 900	lens shield 900	95ASE2005
SG-LS 1050	lens shield 1050	95ASE2006
SG-LS 1200	lens shield 1200	95ASE2007
SG-LS 1350	lens shield 1350	95ASE2008
SG-LS 1500	lens shield 1500	95ASE2009
SG-LS 1650	lens shield 1650	95ASE2010
SG-LS 1800	lens shield 1800	95ASE2011
SG-LS 2	lens shield 2	95ASE2012
SG-LS 3	lens shield 3	95ASE2013
SG-LS 4-900	lens shield 4-900	95ASE2014
SG-LS 4-120	lens shield 4-120	95ASE2015

NOTE: Each package contains what is necessary to protect a single unit (TX or RX). To protect both TX and RX two pieces of the same code are needed

ACCESSORIES

MODEL	DESCRIPTION	ORDER N°
SG-LS-MC4	Elastic fastner for LENS SHIELD (kit 4pcs.)	95ASE1810



The company endeavours to continuously improve and renew its products; for this reason the technical data and contents of this catalogue may undergo variations without prior notice. For correct installation and use, the company can guarantee only the data indicated in the instruction manual supplied with the products.